

INSTALLATION AND OPERATION MANUAL

**12,000 POUND
CAPACITY
FOUR-POST LIFT**

**Models:
HD-12SS
HD-12
HD-12X**



Keep this operation manual near the machine at all times. Make sure that ALL USERS read this manual .

SHIPPING DAMAGE CLAIMS

When this equipment is shipped, title passes to the purchaser upon receipt from the carrier. Consequently, claims for the material damaged in shipment must be made by the purchaser against the transportation company at the time shipment is received.

BE SAFE

Your new lift was designed and built with safety in mind. However, your overall safety can be increased by proper training and thoughtful operation on the part of the operator. DO NOT operate or repair this equipment without reading this manual and the important safety instructions shown inside.

12,000 POUND CAPACITY FOUR POST AUTO / TRUCK LIFT

This instruction manual has been prepared especially for you. Your new lift is the product of over 25 years of continuous research, testing and development and is the most technically advanced lift on the market today.

READ THIS ENTIRE MANUAL BEFORE OPERATION BEGINS.

RECORD HERE THE FOLLOWING INFORMATION
WHICH IS LOCATED ON THE SERIAL NUMBER DATA PLATE

Serial No. _____

Model No. _____

Manufacturing date _____

WARRANTY

Your new lift is warranted for five years on equipment structure; one year on all operating components to the original purchaser, to be free of defects in material and workmanship. The manufacturer shall repair or replace at their option for this period those parts returned to the factory freight prepaid which prove upon inspection to be defective.

The manufacturer will pay labor costs for the first 12 months only on parts returned as previously described.

This warranty does not extend to defects caused by ordinary wear, abuse, misuse, shipping damage, or lack of required maintenance.

This warranty is exclusive and in lieu of all other warranties expressed or implied. In no event shall the manufacturer be liable for special, consequential or incidental damages for the breach or delay in performance of the warranty. The manufacturer reserves the right to make design changes or add improvements to its product line without incurring any obligation to make such changes on product sold previously.

Warranty adjustments within the above stated policies are based on the model and serial number of the equipment. This data must be furnished with all warranty claims.

**WARRANTY IS NOT VALID UNLESS
WARRANTY CARD IS RETURNED**

INTRODUCTION

1. Carefully remove the crating and packing materials. **CAUTION!** Be careful when cutting steel banding material as items may become loose and fall causing personal harm or injury.
2. Inspect the lift for any signs of concealed shipment damage or shortages. Remember to report any shipping damage to the carrier and make a notation on the delivery receipt.
3. Check the voltage, phase and proper amperage requirements for the motor shown on the motor plate. Wiring should be performed by a certified electrician only.

IMPORTANT SAFETY INSTRUCTIONS

Read these safety instructions entirely!

1. **READ AND UNDERSTAND** all safety warning procedures before operating lift.
2. **KEEP HANDS AND FEET CLEAR.** Remove hands and feet from any moving parts. Keep feet clear of lift when lowering. Avoid pinch points.
3. **KEEP WORK AREA CLEAN.** Cluttered work areas invite injuries.
4. Consider work area environment. Do not expose equipment to rain. **DO NOT** use in damp or wet locations. Keep area well lighted.
5. **ONLY TRAINED OPERATORS** should operate this lift. All non-trained personnel should be kept away from work area. Never let non-trained personnel come in contact with, or operate lift.
6. **USE LIFT CORRECTLY.** Use lift in the proper manner. Never use lifting adapters other than what is approved by the manufacturer.
7. **DO NOT** override self-closing lift controls.
8. **REMAIN CLEAR** of lift when raising or lowering vehicle.
9. **CLEAR AREA** if vehicle is on danger of falling.
10. **ALWAYS INSURE** that the safeties are engaged before any attempt is made to work on or near vehicle.
11. **DRESS PROPERLY.** Non-skid steel -toe footwear is recommended when operating lift.
12. **GUARD AGAINST ELECTRIC SHOCK.** This lift must be grounded while in use to protect the operator from electric shock. Never connect the green power cord wire to a live terminal. This is for ground only.
13. **DANGER!** The power unit used on this lift contains high voltage. Disconnect power at the receptacle before performing any electrical repairs. Secure plug so that it cannot be accidentally plugged in during service.
14. **WARNING! RISK OF EXPLOSION.** This equipment has internal arcing or sparking parts which should not be exposed to flammable vapors. This machine should not be located in a recessed area or below floor level.
15. **MAINTAIN WITH CARE.** Keep lift clean for better and safe performance. Follow manual for proper lubrication and maintenance instructions. Keep control handles and/or buttons dry, clean and free from grease and oil.
16. **STAY ALERT.** Watch what you are doing. Use common sense. Be aware.
17. **CHECK FOR DAMAGED PARTS.** Check for alignment of moving parts, breakage of parts or any condition that may affect its operation. Do not use lift if any component is broken or damaged.
18. **NEVER** remove safety related components from the lift. Do not use lift if safety related components are damaged or missing.



THIS SYMBOL POINTS OUT IMPORTANT SAFETY INSTRUCTIONS WHICH IF NOT FOLLOWED COULD ENDANGER THE PERSONAL SAFETY AND/OR PROPERTY OF YOURSELF AND OTHERS AND CAN CAUSE PERSONAL INJURY OR DEATH. READ AND FOLLOW ALL INSTRUCTIONS IN THIS MANUAL BEFORE ATTEMPTING TO OPERATE THIS MACHINE.

TOOLS REQUIRED

- " Rotary Hammer Drill Or Similar (If Anchoring)
- " 3/4" Masonry Bit (If Anchoring)
- " Hammer
- " 4 Foot Level
- " Open-End Wrench Set: 7/16" - 1-1/8"
- " Socket And Ratchet Set: 7/16" - 1-1/8"
- " Hex-Key / Allen Wrench Set
- " Medium Crescent Wrench
- " Medium Pipe Wrench
- " Crow Bar
- " Chalk Line
- " Medium Flat Screwdriver
- " Tape Measure: 25 Foot Minimum
- " Needle Nose Pliers

IMPORTANT NOTICE

Do not attempt to install this lift if you have never been trained on basic automotive lift installation procedures. Never attempt to lift components without proper lifting tools such as forklift or cranes. Stay clear of any moving parts that can fall and cause injury. These instructions must be followed to insure proper installation and operation of your lift. Failure to comply with these instructions can result in serious bodily harm and void product warranty. Manufacturer will assume no liability for loss or damage of any kind, expressed or implied resulting from improper installation or use of this product.

PLEASE READ ENTIRE MANUAL PRIOR TO INSTALLATION.

STEP 1

(Selecting Site)



Before installing your new lift, check the following.

1. **LIFT LOCATION:** Always use architects plans when available. Check layout dimension against floorplan requirements making sure that adequate space is available.
2. **OVERHEAD OBSTRUCTIONS:** The area where the lift will be located should be free of overhead obstructions such as heaters, building supports, electrical lines etc.
3. **DEFECTIVE FLOOR:** Visually inspect the site where the lift is to be installed and check for cracked or defective concrete.

" **DO NOT** install this lift on any asphalt surface or any surface other than concrete.

" **DO NOT** install this lift on expansion seams or on cracked or defective concrete.

" **DO NOT** install this lift on a second / elevated floor without first consulting building architect.

" **DO NOT** install this lift outdoors unless special consideration has been made to protect the power unit from incimate weather conditions.

STEP 2

(Floor Requirements)



This lift must be installed on a solid level concrete floor with no more than 3-degrees of slope. Failure to do so could cause personal injury or death.

A level floor is suggested for proper installation and level lifting. If a floor is of questionable slope, consider a survey of the site and/or the possibility of pouring a new level concrete slab.

CONCRETE SPECIFICATIONS

LIFT MODEL	CONCRETE REQUIREMENT
HD-12SS	4" Min. Thickness
HD-12	4" Min. Thickness
HD-12X	4" Min. Thickness

NOTE

All models **MUST** be installed on 2500 PSI concrete only conforming to the minimum requirements shown above. New concrete must be adequately cured by at least 28 days minimum.

ASSEMBLY VIEW

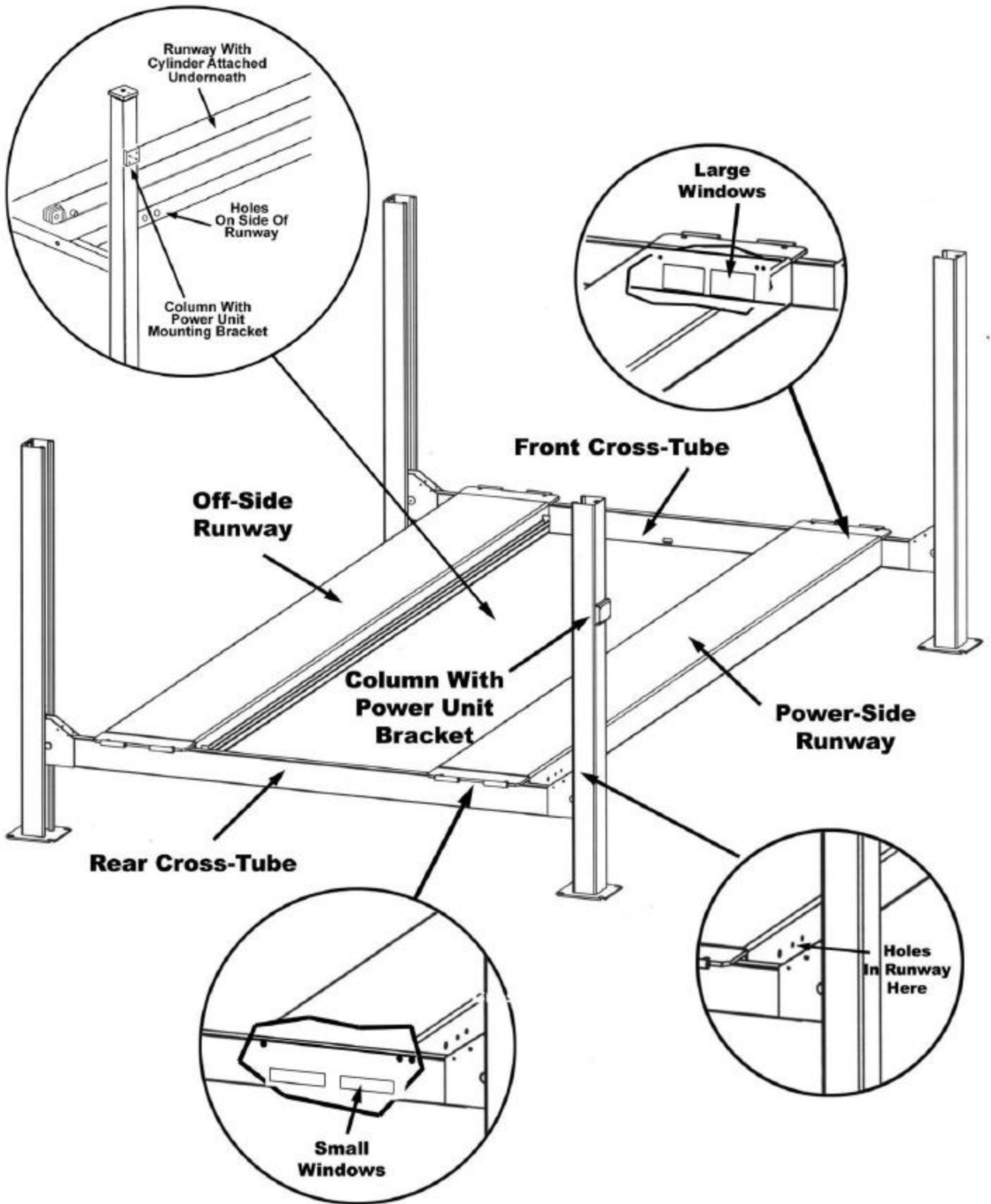

NOTE:
 ENTRY can be made
 on either side of lift.
 The approach ramps
 can be installed at
 either end.

FLOORPLAN

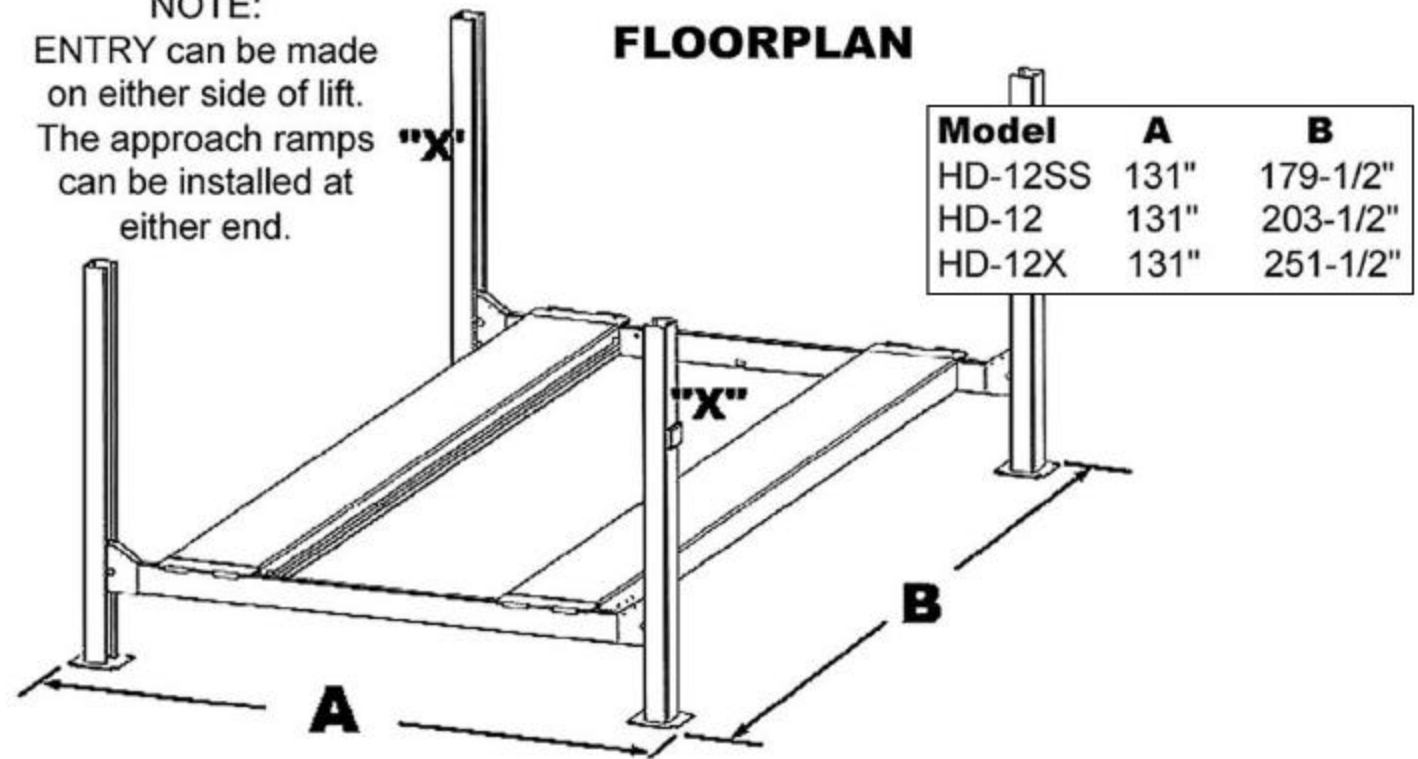

IMPORTANT NOTE

The power unit can be located at either "X" location shown above. It is important to locate the POWER-SIDE runway (with cylinder) on the SAME SIDE as power unit location. Accessory rails on the side of each runway MUST be installed to the inside. For the remainder of this instruction we will illustrate the power unit mounted at the DRIVER-SIDE FRONT column.

STEP 3

(Column & Cross Tube Installation)

1. Locate the columns at their respective locations according to the chalk line layout. (See above) Pay attention to the power unit location. **DO NOT BOLT** columns down at this time. Use caution to prevent columns from falling over. Raise the cross tubes (making sure the plastic slide blocks are still in position) and drop down into the top of the columns. The large cut-out holes should be positioned inward following the diagram on page 5. (See Fig. 1)

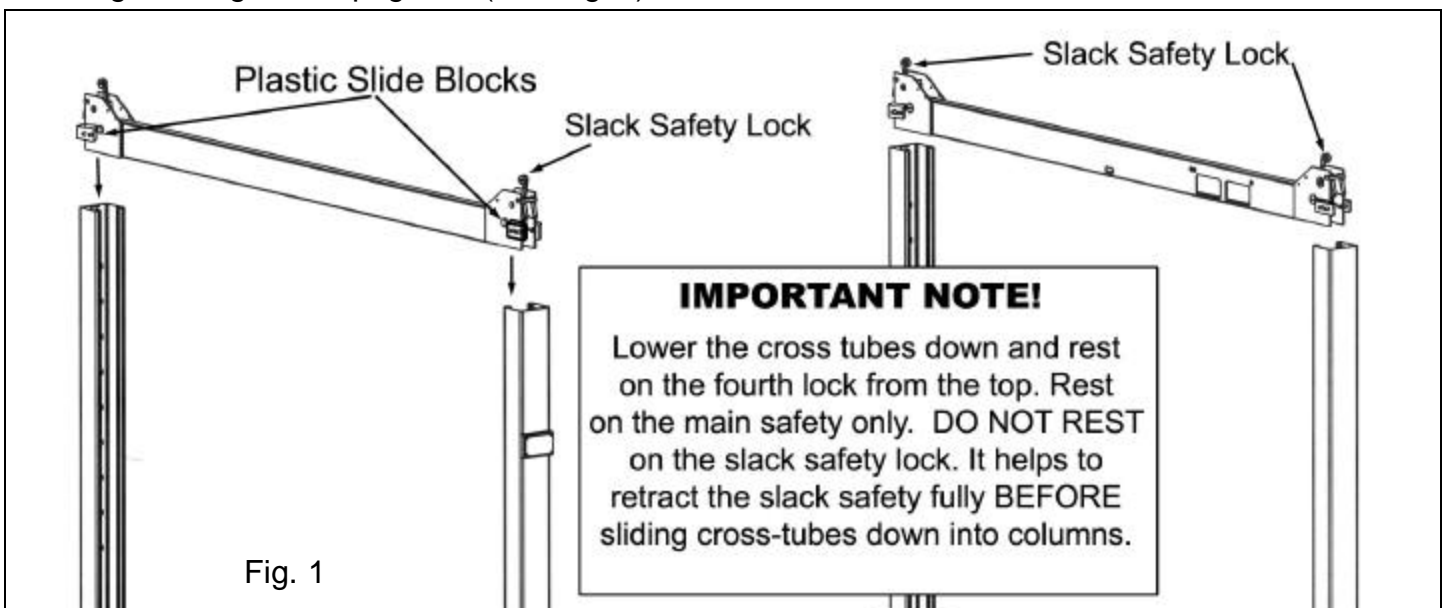
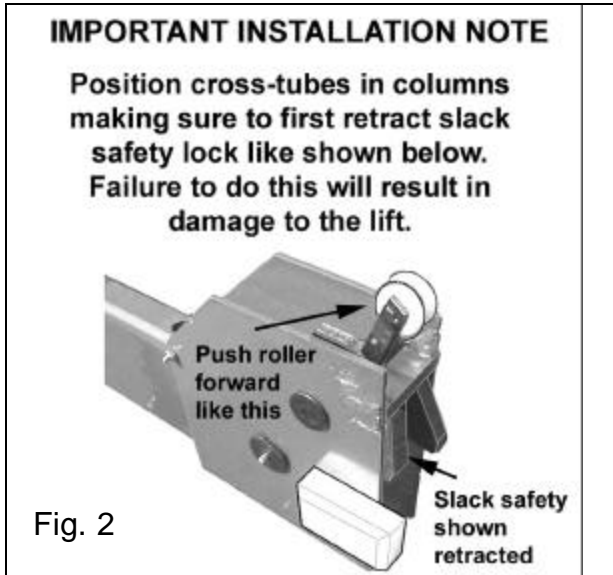
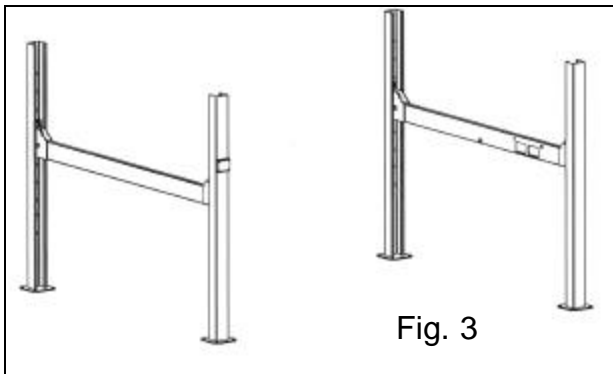

Fig. 1

2. Manually clear the SLACK SAFETY lock devices on the end of each cross tube and slide the cross tubes down until they rest on the safety lock position fourth down from the top of the column. (See Fig. 2)



3. The columns and cross bars will now be in position and spaced properly for the runways. Be very careful not to disturb the columns and cross tubes at this time as they may tip over causing personal injury or harm. (See Fig. 3)



4. With the columns and cross tubes in place, secure the column TOP CAPS using the 3/8" x 1-1/2" Hex bolt, nut & washer. Be sure to position the cable hole INWARD. (See Fig. 4)

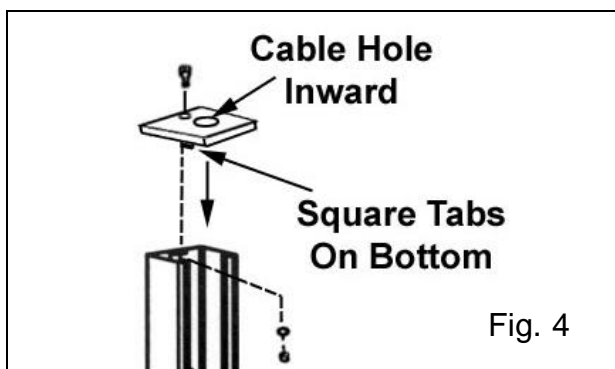

STEP 4

(Anchoring The Columns)

1. Before proceeding, double check the measurements and make certain that the bases of each column are square and aligned with the chalk line.

2. Using the baseplate on each column as a guide, drill each anchor hole approximately 4-1/2" deep using a rotary hammer drill and 3/4" concrete bit. (See Fig. 5)

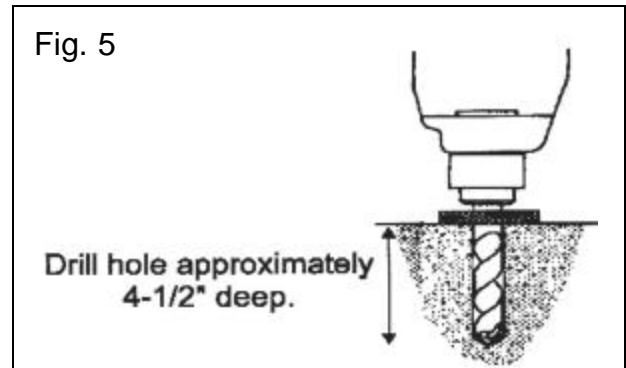

3. After drilling, remove dust thoroughly from each hole using compressed air and/or wire brush. Make certain that the columns remain aligned with the chalk line. Always wear safety goggles.

4. Assemble the washers and nuts on the anchors then tap into each hole with a hammer until the washer rests against the baseplate. Be sure that if shimming is required, enough threads are left exposed. (See Fig. 6)

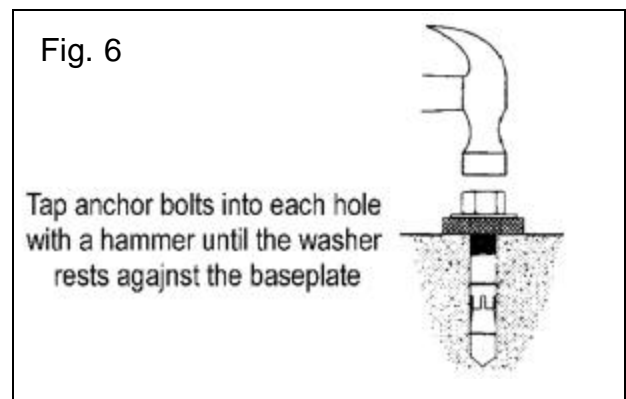

5. If shimming is required, insert the shims as necessary under the baseplate so that when the anchor bolts are tightened, the columns will be plumb. (See Fig. 7)

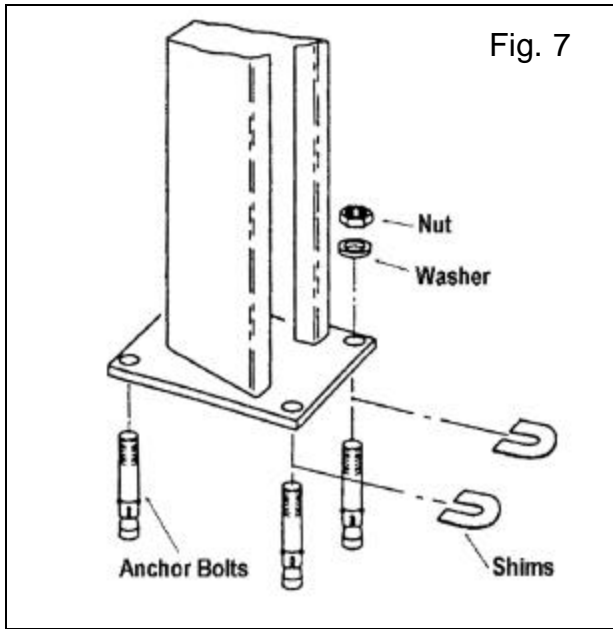

STEP 5

(Runway Installation)

1. Locate the runway with the cylinder attached underneath. This runway will be located adjacent the column with power unit bracket attached.
2. Position the holes on the side of the runway near the power unit location. (See Fig. 8)

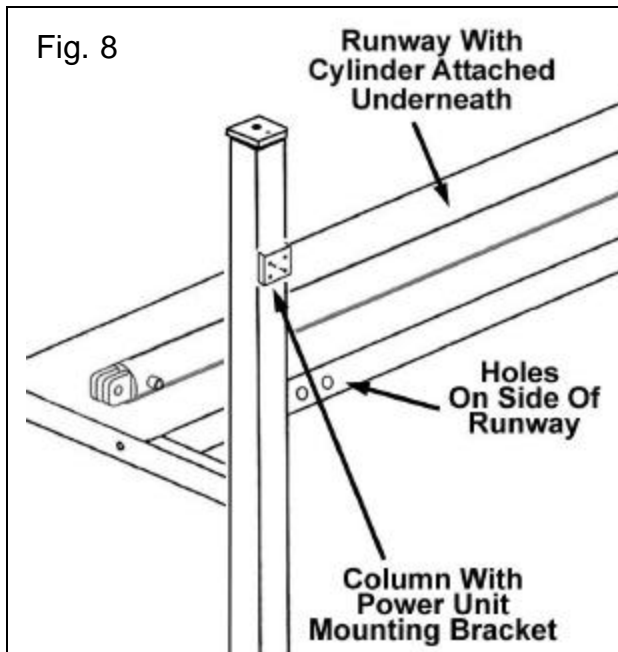

3. Line up the front of the cylinder runway with the cross bar bolt holes then temporarily bolt in position using the 1/2" x 4" hex bolt, nut and lock washers. (See Fig. 9)

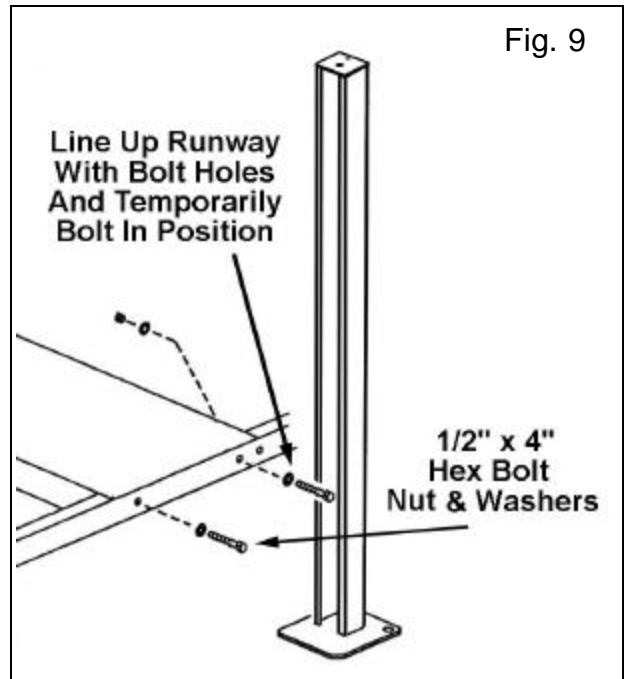

4. Position the offside runway on top of the cross tubes with the utility rails located inside. The offside runway is not bolted down and can be adjusted for different tread width vehicles.

STEP 6

(Cable Installation)

IMPORTANT!

Be careful not to damage the chrome cylinder rod during this operation.

1. Inspect cables to insure proper lengths. All cables should have ID tags showing proper cable lengths.
2. Make sure the cylinder flange plate is installed with the guide-block bracket facing AWAY from the cylinder.
3. In order to install the cables it is necessary to first extend the hydraulic cylinder. Remove the cylinder port plugs then use an air blow gun or come-along to extend the cylinder.
4. You must reinstall the rollers, spacers and cable guards and pins in the same order as they are removed. (See Fig. 10)



The nylon cable nuts MUST be tightened until there is at least 1/4" of threads through the nylon end of the nut. The cables will remain loose until start up.

Fig. 10

IMPORTANT

It will be necessary to remove the pins, cable guards and spacers prior to cable installation. You **MUST** re-install these components back to the same order as they are removed.

Model	A	B	C	D
HD-12SS	128"	191-1/2"	297-1/2"	360-1/2"
HD-12	152"	215-1/2"	345-1/2"	408-1/2"
HD-12X	200"	263-1/2"	441-1/2"	504-1/2"

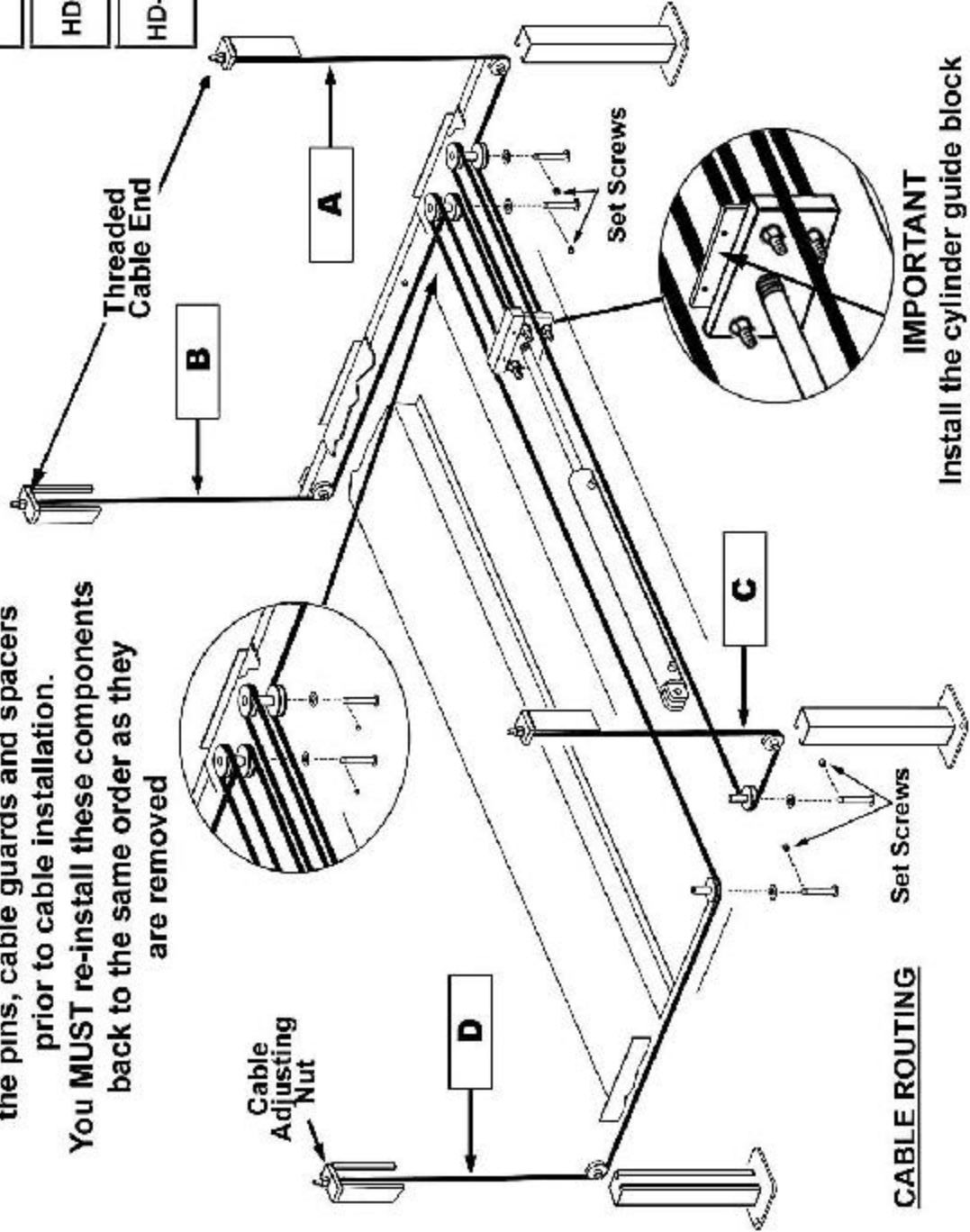

CABLE ROUTING

IMPORTANT
Install the cylinder guide block bracket **AWAY** from cylinder rod as shown here.

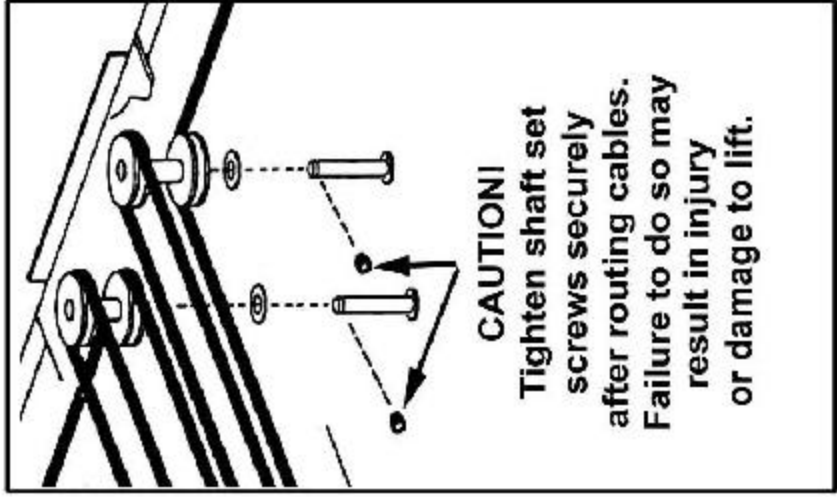

CAUTION!
Tighten shaft set screws **securely** after routing cables. Failure to do so may result in injury or damage to lift.

STEP 7

(Power Unit Installation)

1. Mount the power unit to the mounting bracket using the 5/16" x 3/4" hex bolts and nylon nuts then fill the reservoir with 15 quarts of 10-WT hydraulic oil or Dexron III automatic transmission fluid. (See Fig. 11)

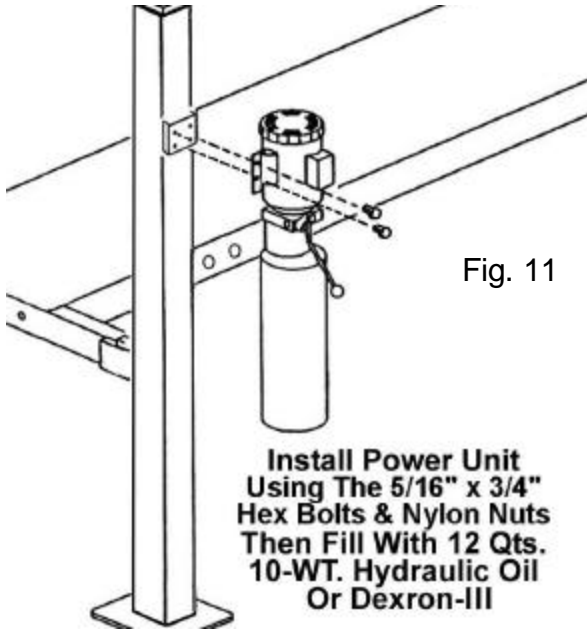

STEP 8

(Routing Hydraulic Hoses)

1. Install the two 90 degree hydraulic fittings to the POWER PORT and RETURN PORT of the power unit and connect the hoses as described below. It will be necessary to remove shipping plugs from both ports prior to installing fittings.

2. Install the two standard bulkhead couplers at the outside of the POWERSIDE RUNWAY adjacent to the power unit. Tighten securely.

3. Install the two 90-degree fittings at the cylinder ports. On the pipe thread side of the fittings it is recommended to use teflon tape or pipe sealer. DO NOT USE TEFLON TAPE on JIC flared end.

4. Connect hydraulic hoses as shown below making sure to first pass through the retaining rings located on the underside of the runway. MAKE SURE HOSES ARE KEPT CLEAR OF CABLES. (See Fig. 12)

HOSE ROUTING

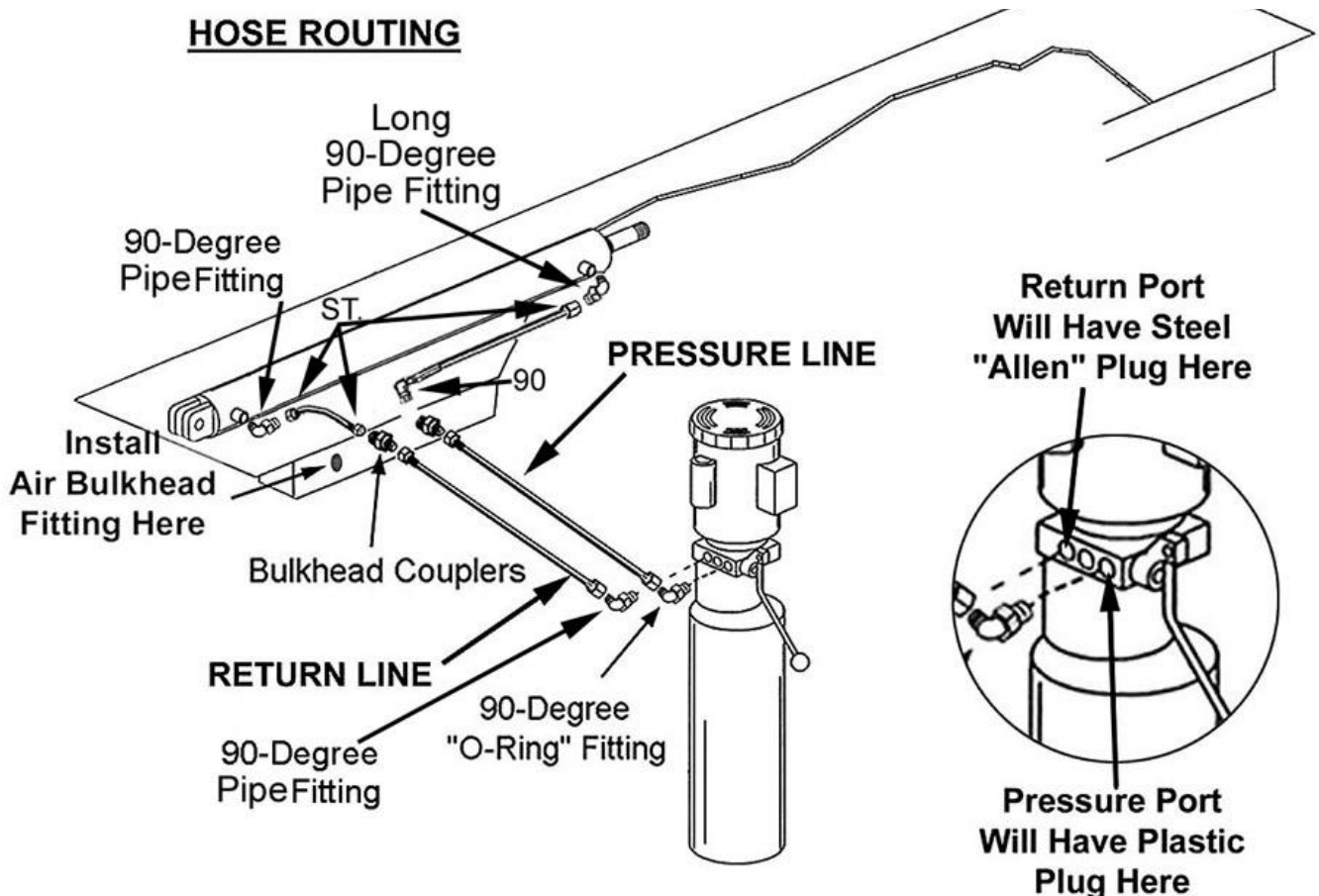

STEP 9

(Routing Airline)

Route the airline as shown below making sure to position the push button air valve with the INLET facing towards the AIR SOURCE and the OUTLET facing the direction of the COILED AIR HOSE. Pay careful attention to keep airline clear of any pinch points. Improper assembly may result in safety lock failure. **AIR PRESSURE SHOULD BE REGULATED TO 125 PSI MAX.** (See Fig. 13)

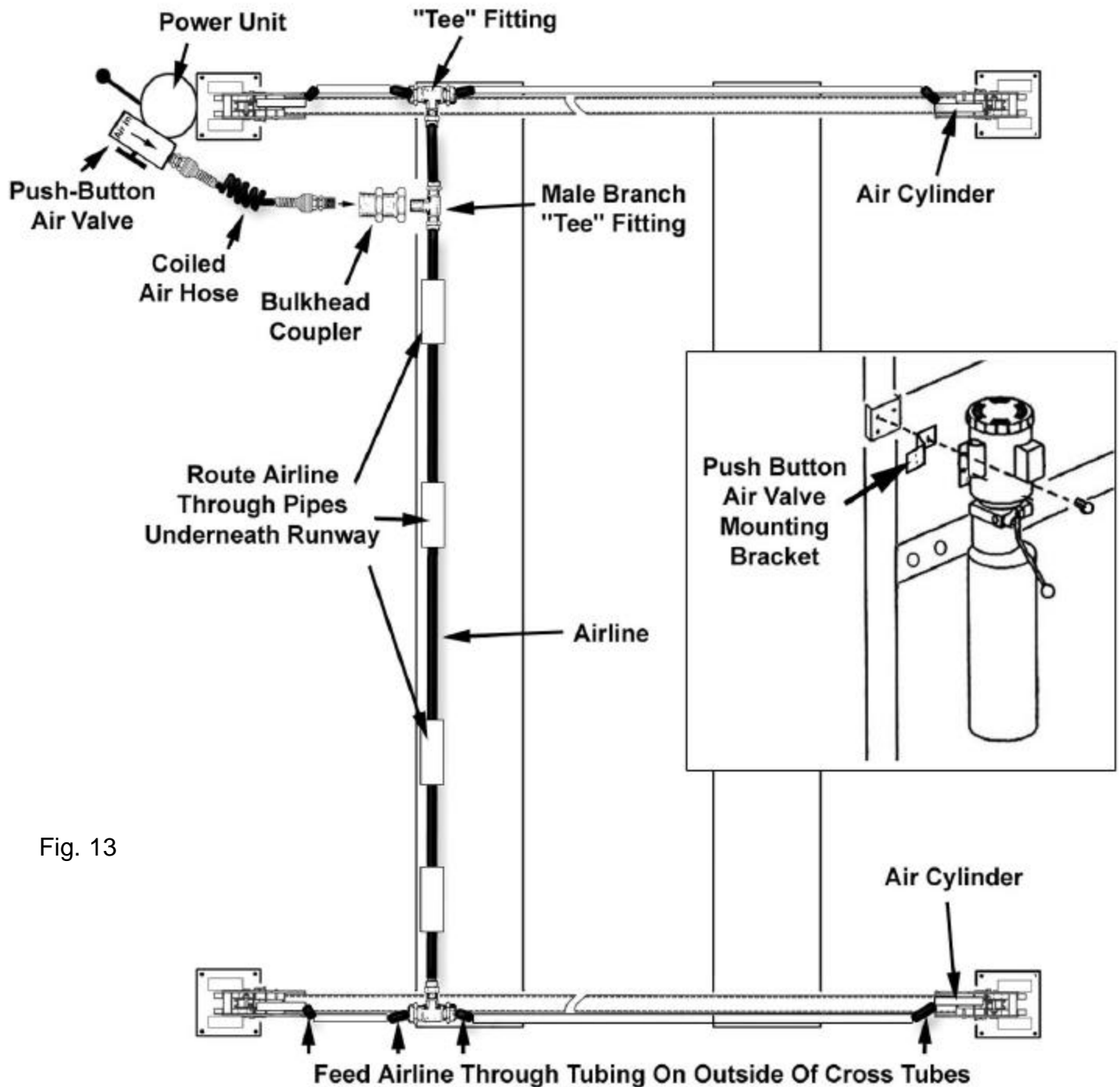

Fig. 13

STEP 10

(Power-Unit Start Up)

1. Have a certified electrician run 208 - 230 volt single phase 60 HZ power supply to motor. (If you ordered optional three phase power refer to the data plate found on the motor for proper power supply.) Be sure to size wire for a 25 amp circuit.



RISK OF EXPLOSION!

This equipment has internal arcing or parts that may spark and should not be exposed to flammable vapors. Motor should not be located in a recessed area or below floor level. NEVER expose motor to rain or other damp environments. **DAMAGE TO MOTOR CAUSED BY WATER IS NOT COVERED UNDER WARRANTY.**

IMPORTANT NOTE:

DO NOT USE 110 VOLT POWER SUPPLY for this power unit. damage to motor will occur which is not covered under warranty. You must use a separate circuit breaker for each lift.

STEP 11

(Lift Start Up)

1. Make sure the power unit reservoir is full with 15 quarts of 10-WT hydraulic oil or Dexron-III automatic transmission fluid.

2. Spray the inside of the columns where the slide blocks glide with a light lubricant or WD-40.

3. Test the power unit by depressing the push-button switch. If the motor sounds like it is operating properly, raise lift and check all hose connections for leaks. **IF MOTOR GETS HOT OR SOUNDS PECULIAR, STOP IMMEDIATELY AND RE-CHECK ELECTRICAL CONNECTIONS.**

4. Once the lift starts to raise, simultaneously press the power unit lowering handle at the same time you are pressing the raise button. This will allow any air trapped in the cylinder and lines to escape and vent into the fluid reservoir.

5. Continue raising the lift slowly until all the slack in the cables is taken out. **RAISE THE LIFT UNTIL THE CYLINDER BOTTOMS OUT AND THE LIFT STOPS. ADJUST EACH CABLE SO THAT THE SAFETY LOCKS REST AT ONE INCH ABOVE THE TOP SAFETY LOCK POSITION.** It may be necessary to tighten or loosen each cable to reach the proper height. The nylon cable nuts **MUST** be tightened on each end until there is at least 1/4" of threads through the nylon end of the nut.

STEP 12

(Installing Slack Safety Springs)



The following steps involve the **SLACK CABLE SAFETY DEVICE** and **MAIN SAFETY**. Failure to follow these steps could result in serious injury or death in the event of cable failure.

1. Install the **SLACK SAFETY LOCK SPRINGS** on the **REAR CROSS TUBE** as shown. Make sure spring ends are secure at both ends. (See Fig. 14)

POWER UNIT

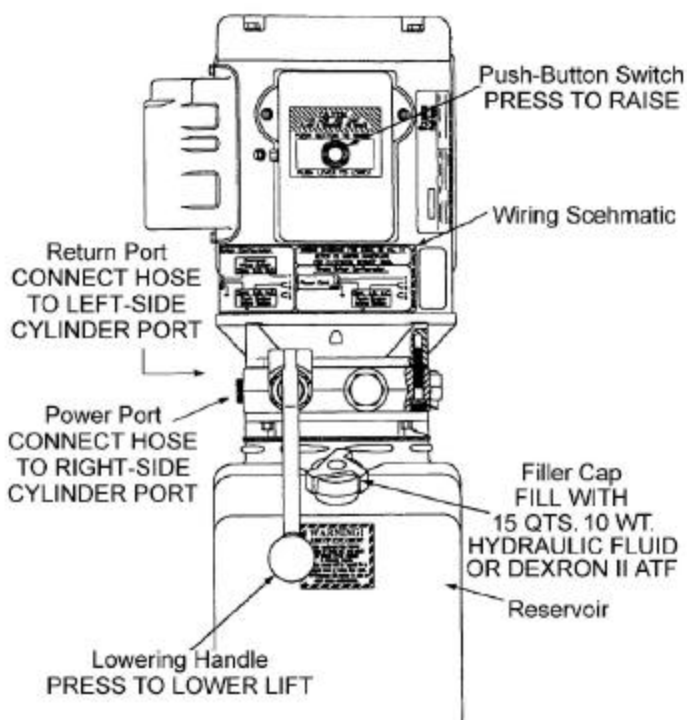

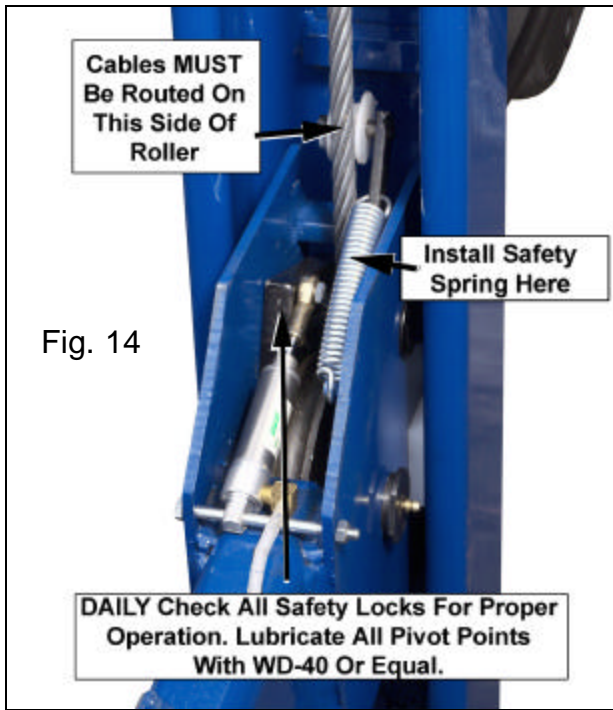

Fig. 14

2. Check all MAIN SAFETY LOCKS to make sure they move freely and spring back to the lock position when released.

3. Lubricate all SAFETY PIVOT points with WD-40 or equal.

STEP 13

(Final Assembly)

1. Tighten the cable adjusting nuts on the top of each column and at the cylinder flange until all remaining safety locks raise to one inch above the top lock position. This will ensure that the cables are adjusted evenly.



The nylon cable nuts MUST be tightened on each end until there is at least 1/4" of threads through the nylon end of the nut. Failure to do so could result in serious injury or death.

2. After connecting the air supply, press the PUSH BUTTON AIR VALVE and check that all safety locks are functioning properly, then lower the lift by pressing the push button air valve and power unit lowering valve simultaneously.

NOTE:

There will be some initial stretching of the cables in the beginning. It will be necessary to re-adjust the cables a week after first use, then every three to six months thereafter.

3. Run the lift up and down a few times to insure that the locks are engaging uniformly and that the safety release mechanisms are functioning properly. Re-adjust if necessary.

4. Install the front tire stops. (See Fig. 15)



Fig. 15

5. Install the approach ramps on the entry side of the lift. Drive a vehicle onto the lift making sure to set the emergency before exiting the vehicle. Run the lift up and down two times with a vehicle to ensure that the locks are engaging uniformly and that the safety release mechanisms are functioning properly. Re-adjust if necessary.

Post-Installation Check-Off

- " Columns Properly Shimmed And Stable
- " Anchor Bolts Tightened
- " Pivot / Roller Pins Properly Attached
- " Electric Power Supply Confirmed
- " Cables Adjusted Properly
- " Safety Locks Functioning Properly
- " Check For Hydraulic Leaks
- " Oil Level
- " Lubrication of Critical Components
- " Check For Overhead Obstructions
- " Runways Level
- " All Screws, Bolts, and Pins Secured
- " Surrounding Area Clean
- " Operation, Maintenance and Safety Manuals on Site

OPERATION:

To Raise Lift;

- " Position vehicle tires in the center of each runway.
- " Set parking brake or use wheel chock to hold vehicle in position.
- " Before raising vehicle, be sure all personnel are clear of the lift and surrounding area. Pay careful attention to overhead clearances.
- " Raise the lift to the desired height by pressing the push button on the power unit.
- " After vehicle is raised to the desired height, lower the lift on the nearest safety lock. Do not allow cables to remain slack.
- " Check to make sure all four safeties are engaged BEFORE ENTERING work area.

To Lower Lift;

- " Raise the lift off the safety locks by pressing the push button on the power unit. Make sure you raise the lift by at least two inches to allow adequate clearance for the locks to clear.
- " Press the push button air safety valve and HOLD.
- " Push the LOWERING HANDLE on the power unit until the lift has descended completely.



When lowering the lift PAY CAREFUL ATTENTION that all personnel and objects are kept clear. ALWAYS keep a visual line of site on the lift AT ALL TIMES. ALWAYS make sure that all FOUR LOCKS are disengaged. If one of the locks inadvertently locks on descent the lift and/or vehicle may disrupt causing personal injury or death.

Weekly Maintenance

- " Lubricate all rollers with general purpose oil or WD-40.
- " Check all cable connections, bolts and pins to insure proper mounting.
- " Lubricate safety lock pivot points with general purpose oil or WD-40.

Monthly Maintenance

- " Check safety locks to insure they are in good operating condition.
- " Check all cables for excessive signs of wear
- " Make a visual inspection of ALL MOVING PARTS and check for excessive signs of wear
- " Replace ALL FAULTY PARTS before lift is put back into operation.

WARNING!

- " **NEVER EXCEED THE RATED CAPACITY** of lift.
- " **DO NOT USE LIFT** if any component is found to be defective or worn.
- " **NEVER OPERATE LIFT** with any person or equipment below.
- " **ALWAYS STAND CLEAR** of lift when lowering or raising.
- " **NEVER OPERATE LIFT** with any person or equipment below.
- " **ALWAYS INSURE SAFETY LOCKS ARE ENGAGED** before entering work area.
- " **NEVER LEAVE LIFT IN ELEVATED CONDITION** unless all four safety locks are engaged.

LIFT WILL NOT RAISE

POSSIBLE CAUSE	REMEDY	INSTRUCTION
1 Air in oil (A, C, J & K)	A Check for proper oil level	The oil level should be up to the bleed screw in the reservoir with lift all the way down.
	B Remove check valve and inspect for contamination	Wash check valve in solvent and blow out with air. Re-install check valve.
2 Cylinder binding (M)	C Bleed cylinders	See installation manual.
3 Cylinder leaks internally (M)	D Flush release to get rid of possible contamination	Hold release handle down and start unit allowing it to run for 15 seconds.
	E Dirty oil	Replace oil with clean Dextron II ATF.
4 Motor runs backwards under pressure (B)	G Tighten all fasteners	Tighten fasteners per engineering specification #2.11.01.
	H Check for free movement of release handle	If handle does not move freely, replace bracket or handle assembly.
5 Lowering valve leaks (D, E, H, N & O)	I Check motor is wired correctly	Compare wiring of motor to electrical diagram on unit.
	J Check inlet tube length	Replace inlet hose assembly.
6 Motor runs backwards (I, & O)	K Oil seal damaged or cocked	Replace oil seal around pump shaft.
	L Relief valve hung up on cap	To remove relief valve and free up valve.
7 Pump damaged (M, N, & O)	M See installation manual	
	N Replace with new part	
8 Pump won't prime (A, J, K, M, O & P)	O Return unit for repair	
	P Check pump mounting bolts	Bolts should be 15 to 18 ft lbs.
9 Relief valve leaks (L, M, N, & O)		
10 Voltage to motor incorrect (I & M)		

MOTOR WILL NOT RUN

POSSIBLE CAUSE	REMEDY	INSTRUCTION
1 Fuse blown (E,B,A,C & D)	A Check for correct voltage	Compare supply voltage with voltage on motor nametag. Check that the wire is sized correctly. N.E.C. table 310 - 12 requires AWG 10 for 30A.
	2 Limit switch burned out (A,B,C & D)	
3 Microswitch burned out (A,B,C & D)	C Don't use extension cords	According to N.E.C. section 210-6 paragraph D: "The size of the conductors...should be such that the voltage drop would not exceed 3% to the farthest outlet for power..."
	4 Motor burned out (A,B,C,D & F)	
5 Voltage to motor incorrect (B & A)	E Reset circuit breaker / fuse	
	F Return unit for repair	
	G See installation manual	

WILL NOT RAISE LOADED LIFT

POSSIBLE CAUSE	REMEDY	INSTRUCTION
1 Air in oil (A, B, D & F)	A Check oil level	The oil level should be up to the bleed screw in the reservoir with the lift all the way down.
2 Cylinder binding (G)	B Check/tighten inlet tubes	Replace inlet hose assembly and suction cover.
	D Oil seal damaged or cocked	Replace oil seal and install according to sheet #8.3.2.
3 Cylinder leaks internally (G)	E Remove check valve and inspect for contamination	Wash check valve in solvent and blow out with air. Re-install check valve.
	F Bleed cylinders	Refer to installation manual.
4 Lift overloaded (G & H)	G See installation manual	
	H Check vehicle weight	Compare weight of vehicle to weight limit of the lift.
5 Lowering valve leaks (I, J, K, A & G)	I Flush valve	Hold release handle down and start unit allowing it to run for 15 seconds.
	J Replace with new part	
6 Motor runs backwards (E, K & L)	K Return unit for repair	
	L Check motor is wired correctly	Compare wiring of motor to electrical diagram on unit drawing.
7 Pump damaged (G, J & K)	M Relief valve hung up	Remove cap and free up, blow out with air.
8 Pump won't prime (A, B, D, F, G & K)		
9 Relief pressure incorrect (G, J & K)		
10 Relief valve leaks (M, J, K & G)		
11 Voltage to motor incorrect (L & G)		

LIFT WILL NOT STAY UP

POSSIBLE CAUSE	REMEDY	INSTRUCTION
1 Air in oil (A, D & F)	A Check oil level	The oil level should be up to the bleed screw in the reservoir with the lift all the way down.
	D Oil seal damaged or cocked	Replace oil seal around pump shaft.
2 Check valve leaks (E, H, I & J)	E Remove check valve and inspect for contamination	Wash check valve in solvent and blow out with air. Re-install check valve.
	F Bleed cylinders	Refer to installation manual.
3 Cylinder leaks Internally (J)	G Flush valve	Hold release handle down and start unit allowing it to run for 15 seconds.
	H Replace with new part	
4 Lowering valve leaks (G, H, I, A & J)	I Return unit for repair	
	J See installation manual	
5 Leaking fittings (K)	K Check complete hydraulic system for leaks	

LIFT LOWERS SLOWLY OR NOT AT ALL

POSSIBLE CAUSE	REMEDY	INSTRUCTION
1 Cylinder binding (A)	A See installation manual	
	B Replace with new part	
	C Return unit for repair	
2 Release valve screen clogged (E, B, D & C)	D Use clean Dextron II ATF only	If ATF is contaminated, replace with clean ATF.
	E Clean release valve screen	Wash release valve in solvent and blow out with air.



Over 35 Years of Excellence



**For Parts Or Service
Contact:**

**Bend-Pak Inc. / Ranger Products
1645 Lemonwood Dr.
Santa Paula, CA. 93060**

**Tel: 1-805-933-9970
Fax: 1-805-933-9160**

www.bendpak.com